

## PARTS LIST

MODEL : LM535 KX.KS (WHEEL)

'89 Spec.

Jan. 25, 1991

E. Kanoh

1 / 2

REF. NO.	PARTS NO.	PARTS NAME	Q'TY	PRICE(¥)	Q'TY /100 SETS /YEAR	REMARKS
1	51043-112	HOUSING	1		3	
2	11142-102	ADJUSTER	1		3	(L)
3	11142-103	ADJUSTER	1		3	(R)
4	71041-103	WHEEL ASS'Y	2		6	
5	91086-102	TIRE	(1)		15	
6	36107-102	WHEEL	(1)		3	
7	932L0696	BEARING	((2))		10	
8	36070-110	CAP	2		6	
9	68036-101	WASHER	2		6	
10	664V0626	WAVE SPRING WASHER	2		6	
11	335L0815	FLANGE BOLT	M8x15	2	6	
12	11150-101	ADJUST LEVER	2		6	
13	36061-121	KNOB	2		6	
14	31057-132	HEXAGON BOLT	2		6	
15	569L0800	FLANGE NYLON NUT	M8	2	6	
16	71122-101	ADJUSTER ASS'Y	1		3	(L)
17	11142-104	ADJUSTER	(1)		3	
18	932L0630	BEARING	(1)		5	
19	71122-102	ADJUSTER ASS'Y	1		3	(R)
20	11142-105	ADJUSTER	(1)		3	
21	932L0630	BEARING	(1)		5	
22	71041-104	WHEEL ASS'Y	2		6	
23	91086-102	TIRE	(1)		15	
24	36107-101	WHEEL	(1)		3	
25	71158-101	RATCHET ASS'Y	1		3	(R)
26	11102-138	HOLDER	(1)		3	
27	68013-170	SPRING	(1)		5	
28	31034-123	PIN	(2)		6	
29	71158-102	RATCHET ASS'Y	1		3	(L)
30	11102-138	HOLDER	(1)		3	



① 71008-203(GEAR CASE ASS'Y)

② 51001-195  
 ③ 61002-163  
 ④ 31057-126  
 ⑤ 68001-107  
 ⑥ 61002-161

⑦ 717 B 0418  
 ⑧ 812 V 1800  
 ⑨ 91097-101

⑩ 11097-106  
 ⑪ 61024-117  
 ⑫ 78001-128  
 ⑬ 11129-104

⑭ 61024-121  
 ⑮ 78003-111  
 ⑯ 61002-162  
 ⑰ 320 M 0630  
 ⑱ 11104-137  
 ⑲ 11083-201(2)  
 ⑳ 613 L 0600  
 ㉑ 571 L 0600

⑳ 64014-181  
 ㉒ 214 B 11000  
 ㉓ 68013-167  
 ㉔ 31034-122  
 ㉕ 64014-157  
 ㉖ 61024-118  
 ㉗ 78004-139  
 ㉘ 78004-140  
 ㉙ 61024-118  
 ㉚ 51001-196  
 ㉛ 64024-104  
 ㉜ 315 L 0625(3)  
 ㉝ 61002-162  
 ㉞ 61002-163  
 ㉟ 11006-101  
 ㊱ 318 L 0612  
 ㊲ 315 L 0635(2)  
 ㊳ 78012-107  
 ㊴ 11104-119  
 ㊵ 320 L 0525

㊶ 64014-163  
 ㊷ 719 B 0620

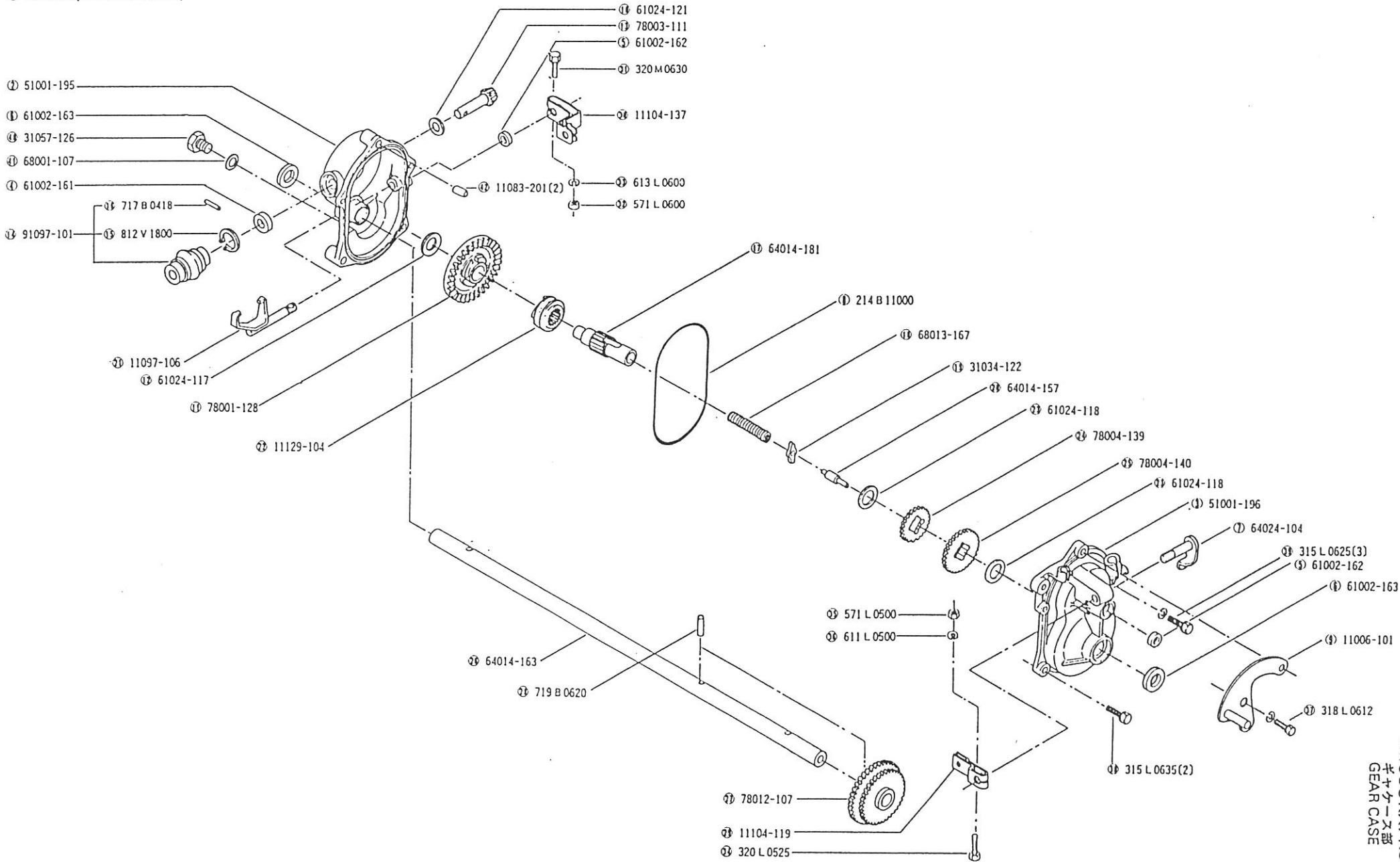

MODEL '89  
 LM535KX, KS  
 ギヤケース  
 GEAR CASE

## PARTS LIST

MODEL : LM535 KX,KS (GEAR CASE)

'89 Spec.

Jan. 25,1991

E.Kanoh

1 / 2

REF. NO.	PARTS NO.	PARTS NAME	Q'TY	PRICE(¥)	Q'TY /100 SETS /YEAR	REMARKS
1	71008-203	GEAR CASE ASS'Y	1		3	
2	51001-195	GEAR CASE	(1)		3	
3	51001-196	GEAR CASE	(1)		3	
4	61002-161	OIL SEAL SD 10 20 5	(1)		5	
5	61002-162	OIL SEAL SD 8 14 4	(2)		10	
6	61002-163	OIL SEAL SD 15 24 5	(2)		10	
7	64024-104	SHIFTER SHAFT	(1)		3	
8	214B11000	O-RING	(1)		5	
9	11006-101	STAY C.P.	(1)		3	
10	61024-121	SPACER	(1)		5	
11	78001-128	BEVEL GEAR	(1)		3	
12	61024-117	SPACER	(1)		5	
13	78003-111	PINION	(1)		3	
14	91097-101	UNIVERSAL JOINT	(1)		3	
15	812V1800	C-SNAP RING FOR SHAFT $\phi 18$	((1))		1	
16	717B0418	PARALLEL PIN $\phi 4 \times 18$	((1))		3	
17	64014-181	SHAFT	(1)		3	
18	68013-167	SPRING	(1)		3	
19	31034-122	PIN	(1)		3	
20	64014-157	SHAFT	(1)		3	
21	11097-106	SHIFTER FORK	(1)		3	
22	11129-104	CLUTCH	(1)		3	
23	61024-118	SPACER	(2)		6	
24	78004-139	GEAR	(1)		3	
25	78004-140	GEAR	(1)		3	
26	64014-163	SHAFT	(1)		3	
27	78012-107	GEAR C.P.	(1)		3	
28	719B0620	PARALLEL PIN $\phi 6 \times 20$	(1)		3	
29	11104-119	ARM	(1)		3	
30	11104-137	ARM	(1)		3	



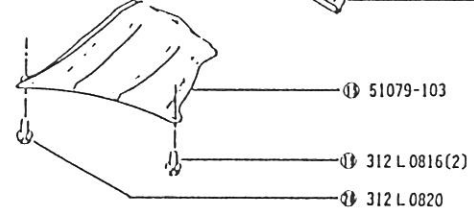
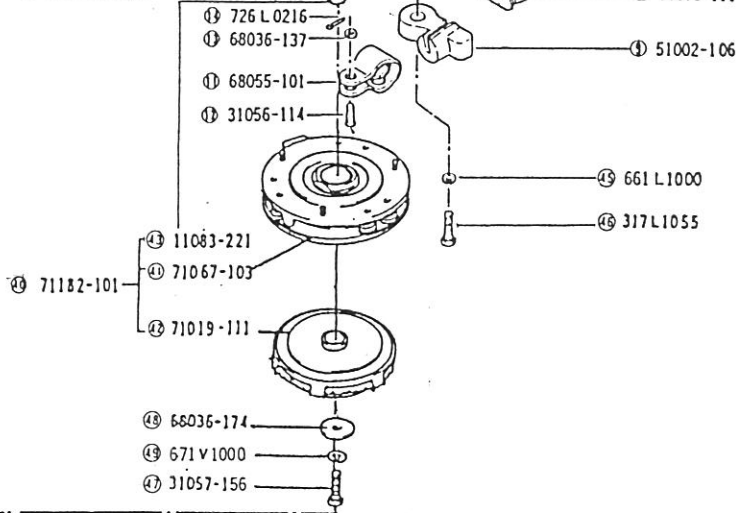
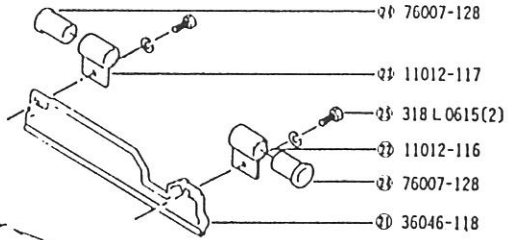
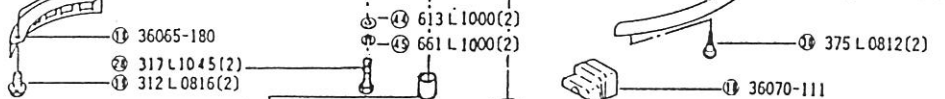
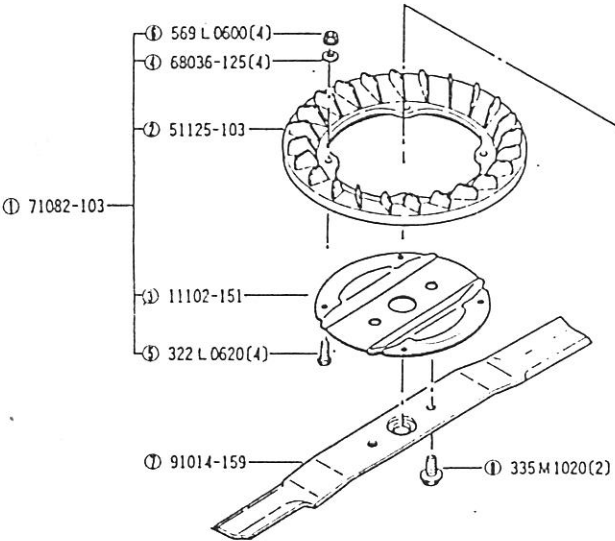
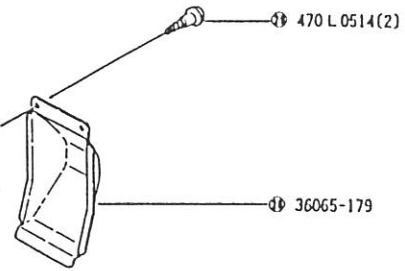
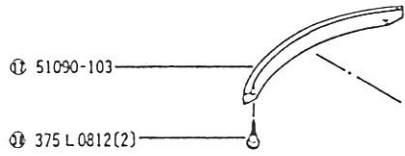
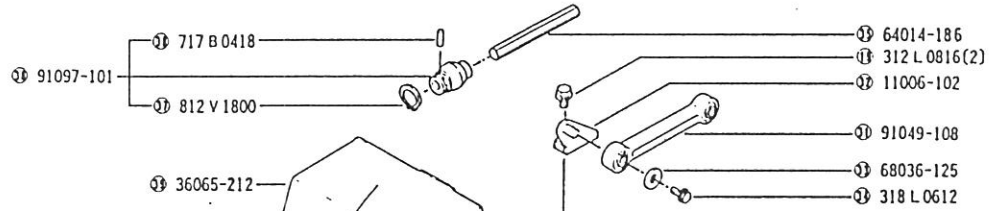
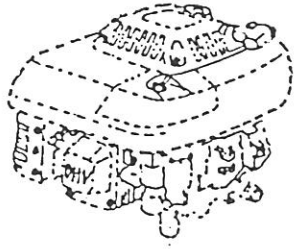

MODEL 89  
LM535KX  
刈草部  
GRASS-CUTTING

## PARTS LIST

MODEL : LM535 KX (GRASS-CUTTING)

'89 Spec.

Jan. 25, 1991 E. Kanoh 1 / 2

REF. NO.	PARTS NO.	PARTS NAME	Q'TY	PRICE(¥)	Q'TY /100 SETS /YEAR	REMARKS
1	71082-103	FAN ASS'Y	1		3	
2	51125-103	FAN	(1)		5	
3	11102-151	HOLDER	(1)		5	
4	68036-125	WASHER	(4)		12	
5	322L0620	(+) HEXAGON BOLT M6x20	(4)		20	
6	569L0600	FLANGE NYLON NUT M6	(4)		12	
7	91014-159	BLADE	1		15	
8	335M1020	FLANGE BOLT M10x20	2		30	
9	51002-106	WIRE HOLDER	1		3	
10	36070-111	CAP	1		3	
11	68055-101	JOINT	1		10	
12	31056-114	GIB-HEADED PIN	1		10	
13	68036-137	WASHER	1		10	
14	726L0216	SPLIT PIN $\phi$ 2x16	1		10	
15	51079-103	COVER C.P.	1		5	
16	51090-102	PROTECTOR	1		3	(L)
17	51090-103	PROTECTOR	1		3	(R)
18	36065-180	COVER	1		3	
19	312L0816	HEXAGON BOLT M8x16 (W/SW)	6		72	
20	312L0820	HEXAGON BOLT M8x20 (W/SW)	1		12	
21	36046-118	SAFETY GUARD	1		3	
22	11012-116	HANGER BAND	1		3	(L)
23	11012-117	HANGER BAND	1		3	(R)
24	76007-128	BUSH	2		30	
25	318L0615	(+) HEXAGON BOLT M6x15 (W/SW)	2		6	
26	36065-179	COVER	1		3	
28	317L1045	HEXAGON BOLT M10x45	2		6	
29	470L0514	(+) TAPPING SCREW M5x14	2		6	
30	375L0812	(+) SCREW M8x12 (W/SW)	4		48	
31	91049-108	CONNECTOR	1		3	





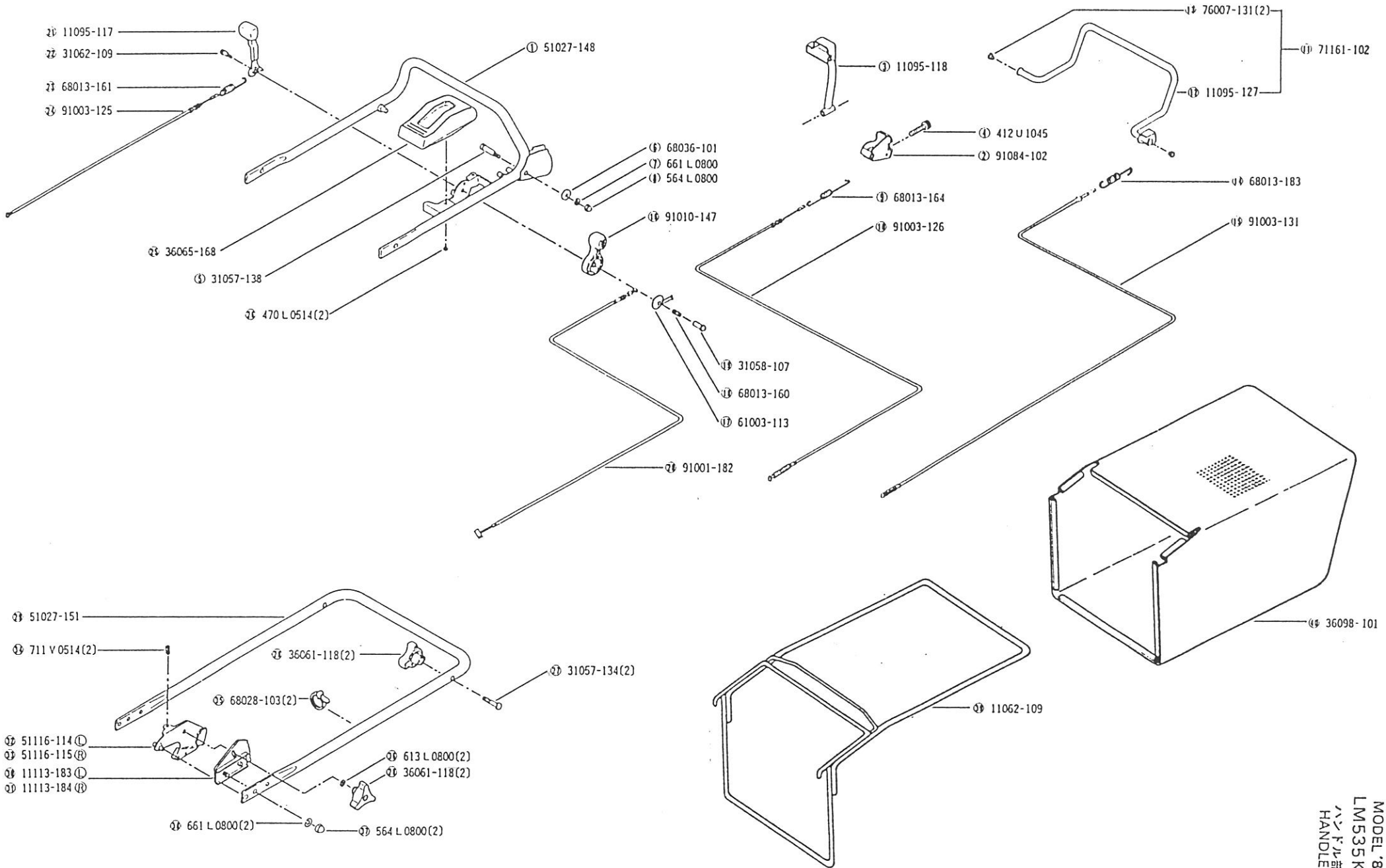

## PARTS LIST

MODEL : LM535 KX (HANDLE)

'89 Spec.

Jan. 25, 1991

E. Kanoh

1 / 2

REF. NO.	PARTS NO.	PARTS NAME	Q'TY	PRICE(¥)	Q'TY /100 SETS /YEAR	REMARKS
1	51027-148	HANDLE	1		3	
2	91084-102	JOINT LINK	1		5	
3	11095-118	LEVER	1		10	
4	412U1045	SOCKET SCREW M10x45	1		10	
5	31057-138	HEXAGON BOLT	1		10	
6	68036-101	WASHER	1		3	
7	661L0800	SPRING LOCK WASHER M8	1		3	
8	564L0800	HEXAGON CAP NUT M8	1		3	
9	68013-164	SPRING	1		5	
10	91003-126	CONTROL CABLE 1) 刀	1		15	
11	71161-102	LEVER ASS'Y	1		5	
12	11095-127	LEVER	(1)		3	
13	76007-131	BUSH	(2)		30	
14	68013-183	SPRING	1		5	
15	91003-131	CONTROL CABLE 走行	1		5	
16	91010-147	THROTTLE LEVER	1		10	
17	61003-113	THRUST PLATE	1		5	
18	68013-160	SPRING	1		3	
19	31058-107	HEXAGON NUT	1		3	
20	91001-182	THROTTLE WIRE	1		10	
21	11095-117	LEVER	1		3	
22	31062-109	LOCK HEXAGON BOLT	1		5	
23	68013-161	SPRING	1		3	
24	91003-125	CONTROL CABLE 高他	1		5	
25	36065-168	COVER	1		3	
26	470L0514	(+) TAPPING SCREW M5x14	2		6	
27	31057-134	BOLT	2		6	
28	36061-118	KNOB	4		12	
29	51027-151	HANDLE	1		3	
30	11113-183	STAY	1		3	(L)

